

Learn more about ATEX and intrinsically safety.

Extreme care must be taken whenever working in oil and gas production. Flammable gases and air may constitute explosive mixtures that can be ignited by sparks or high temperatures. Instruments that are used where flammable petroleum gases or volatile liquids are produced, must be intrinsically safe and explosion proof to prevent fatal incidents.

International standards are in place to assure this life threatening danger remains contained and does not come to effect. ATEX (ATmosphères EXplosibles) is the most common directive applicable to instrumentation used in areas exposed to explosive hazards.

ATEX compliance is monitored by notified bodies such as the TUV. A notified body is an inspection organization that has been audited by an approved and designated national body to approve its competency in relation to a European standard such as ATEX. A notified body is universally acceptable throughout the EU.

Sonoecho™ fluid level recorders and dynamometers are ATEX certified. If the operator wants to know whether a product is ATEX compliant he should ask the supplier for two certificates.

1. EU-Type-Examination Certificate
2. ATEX Production Quality Assurance Notification

While the EC-Type-Examination Certificate guarantees that the design of the instrument is in compliance with ATEX regulations, the Production Quality Assurance Notification guarantees that each and every instrument is manufactured according to the ATEX approved design.

Example documents



Example of EU-Type Examination Certificate

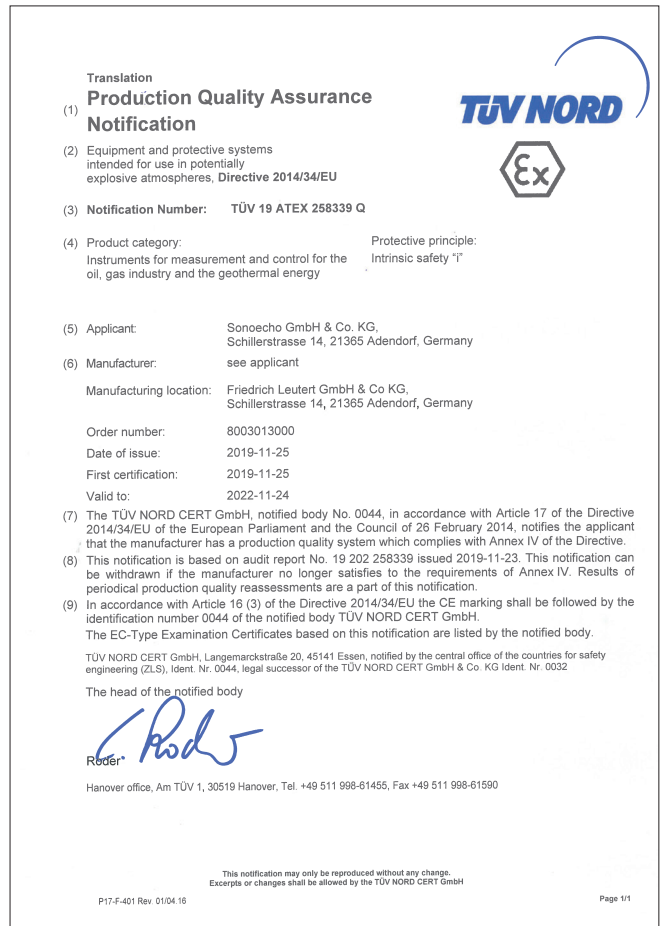

Example of Production Quality Assurance Notification

ATEX certified sonoecho™ fluid level recorder and dynamometer



sonoecho™
 Liquid Level Gun 3000 PSI



sonoecho™
 Dynamometer Dyn17

The certificates must cover all components of a dynamometer, this includes wireless transmitters and pressure sensors. No certificates, no ATEX. Furthermore maintenance, repair and/or reconditioning must be performed by sonoecho™ trained personnel only otherwise the ATEX certification becomes invalid.

In case you want to check whether the dynamometer or sonoecho is going to be used in an explosive area, you should consult local or international recommendations for classification of areas exposed to explosive hazards, e.g. the German BVEG publishes recommendations for classifying areas exposed to explosive hazards. The API-RP500 classifies hazardous zones for a rod pumped well. Equivalent standards exist throughout the world.

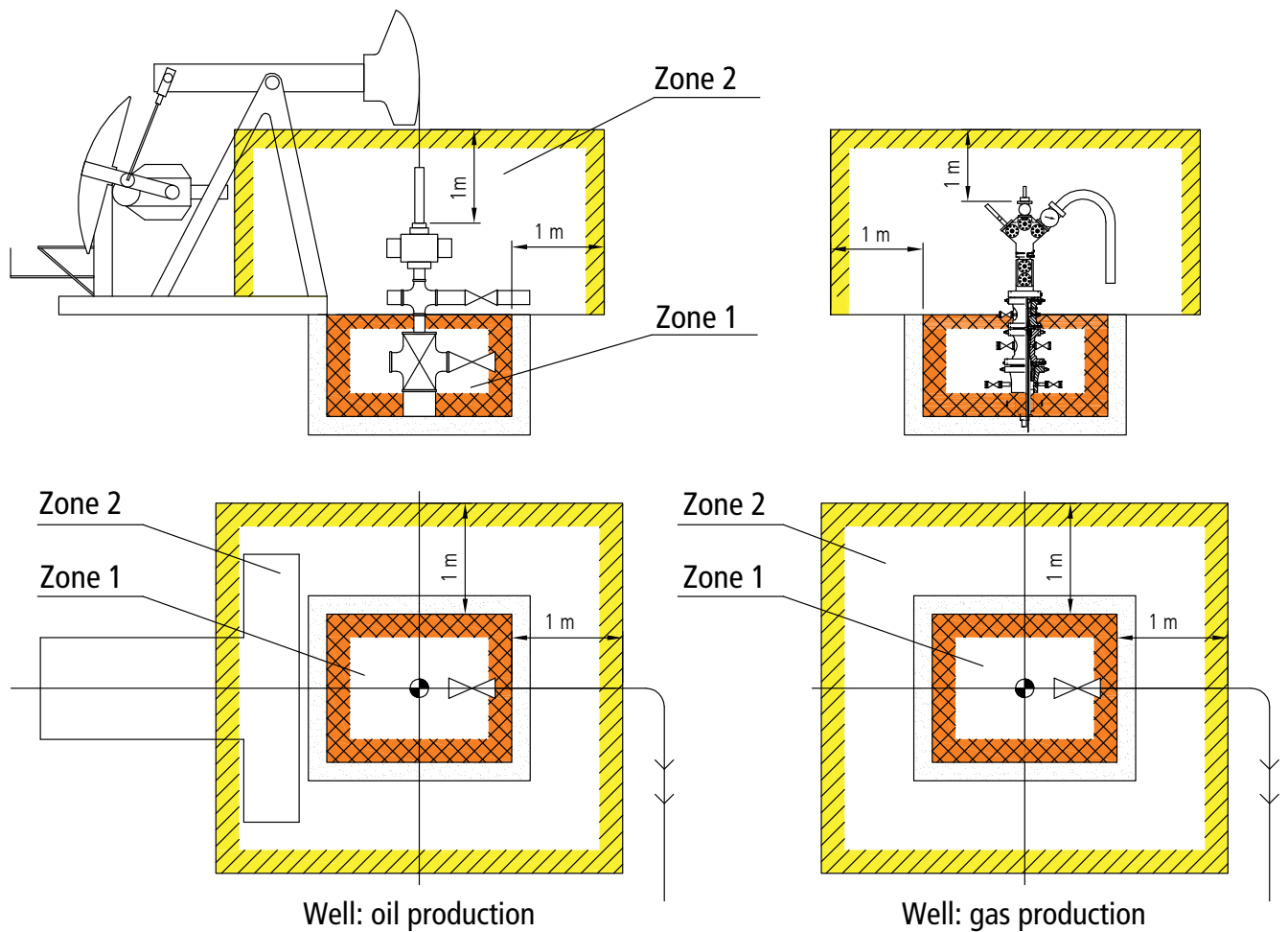

BVEG Recommendations for establishing areas exposed to explosive hazards.

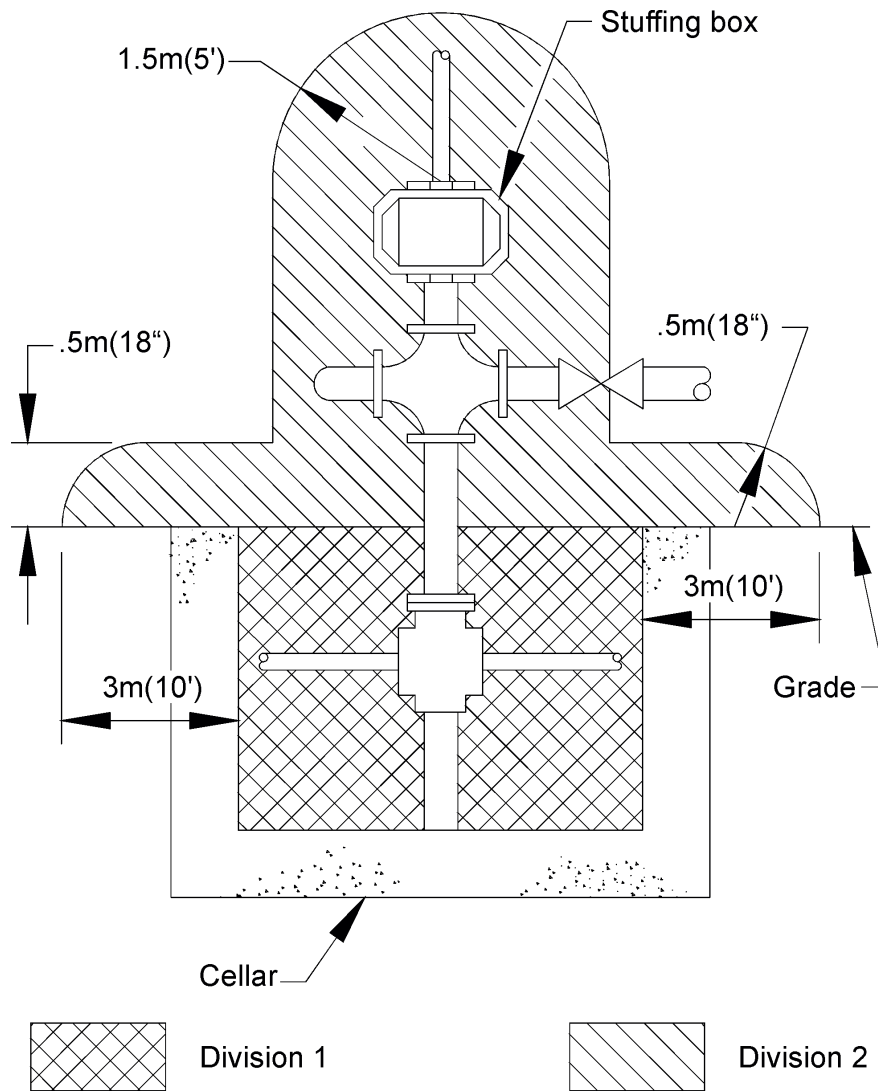

Classification of hazardous zones for a rod pumped well according to API-RP500